

# Possessor case in Udmurt

Anke Assmann anke.assmann@uni-leipzig.de	Doreen Georgi georgi@uni-leipzig.de
Timo Klein timo.klein@uni-leipzig.de	Philipp Weisser philipp.weisser@uni-leipzig.de

## 1 Introduction

### *Observation:*

In Udmurt (Uralic), the possessor bears either genitive or ablative. The case values are in complementary distribution: According to the literature, genitive is the default possessor case; ablative occurs if the DP that contains the possessor functions as a direct object, cf. (1) (Csucs (1988); Kel'makov (1993); Vilkuna (1997); Winkler (2001); Nikolaeva (2002); Koptjevskaja-Tamm (2003); Suihkonen (2005); Edygarova (2009)). **The case value of the possessor thus seems to depend on the external head** that selects the DP containing the possessor (DP is selected by V vs. some other head).

### (1) *Possessor cases in Udmurt:*

- a. so-len/\*leš anaj-ez siče ug dišaški  
he-GEN/ABL mother-3SG such dress NEG.PRES.3SG  
'His mother does not dress such a way.' (Edygarova (2009, 105))
- b. so-leš/\*-len eš-s-e ažžiško  
he-ABL/GEN friend-3SG-ACC see.PRES.1SG  
'I see his friend.' (Edygarova (2009, 101))

Possessor case splits that depend on the nature of the external head exist in other languages as well, e.g., in Bezhta (Daghestanian): The possessor receives the so-called *direct genitive* if the entire DP is assigned nominative case; otherwise, the possessor gets the so-called *oblique genitive*.

### (2) Bezhta (Kibrik, 1995, 20):

- a. abo-s is  
father-GEN<sub>dir</sub> brother.NOM  
'father's brother'
- b. abo-la is-t'i-l  
father-GEN<sub>obl</sub> brother-OBL-DAT  
'to father's brother'
- c. is-t'i-la biLo-ʔ  
brother-OBL-GEN<sub>obl</sub> house-INCESS  
'in the brother's house'

In what follows, we concentrate on the case split in Udmurt.

*Problems and Questions:*

- Given a strictly derivational bottom-up syntax, the relevant information about the grammatical function (GF) of the DP containing the possessor is not available at the point of case assignment to the possessor in the DP. The decision which case to assign to the possessor thus seems to require **look-ahead** or a non-local dependency.
- **Why** is the alternative possessor case **ablative** and not some other case?

*Claim:*

According to the literature, it is the GF of the DP containing the possessor that is decisive for the case split. However, the term “direct object” is never precisely defined. By testing several possible interpretations of “direct object”, we argue that **the case split in Udmurt does not depend on GFs**; rather, it is driven by the case value that the DP containing the possessor is assigned.

(3) *Empirical generalization:*

The possessor in Udmurt bears ablative if the DP in which the possessor is contained is assigned accusative. It bears genitive elsewhere.

This new generalization facilitates a reanalysis of the case split in Udmurt that does not require look-ahead.

*Main idea of the analysis: syntactic but no morphological case stacking*

- Nominal elements in Udmurt bear two case slots (syntactic case stacking).
- Possessors are always assigned genitive case in the DP.
- Additionally, the possessor can be assigned a structural case (nom, acc, gen).
- Morphologically, only one case slot can be realized by a marker. Thus, the two case values on the possessor fuse into a single feature set in the postsyntactic morphological component. This set is realized by the most specific matching marker.
- Consequence: The combination of genitive and accusative yields the abstract representation of a semantic case. The most specific matching marker is the ablative marker, which is the default semantic case in Udmurt.

*Outline:*

This paper ...

1. discusses the locality problem that case assignment in Udmurt seems to pose.
2. determines the exact distribution of the ablative case.
3. presents a local analysis that derives the generalization.
4. discusses the empirical and theoretical consequences of the analysis.

## 2 A non-local case dependency?

*Two main assumptions:*

1. All syntactic dependencies are local.
2. The case values are only manipulated at the point of case assignment.

Under a strictly derivational model of grammar in which the structure unfolds step by step in a bottom-up fashion (e.g. in minimalism, cf. Chomsky (1995) et seq.), case assignment to the possessor in Udmurt faces a look-ahead problem:

- The possessor gets its case within the DP containing the possessor and possessum.
- The choice of the concrete case value seems to depend on the GF of the entire DP.
- GFs are determined by the position of the DP in the structure, i.e., a DP is a direct object if it is the sister of V.
- The information about the structural position of the entire DP is not available at the point of case assignment within the DP: the entire DP is merged into the structure only after case assignment to the possessor took place:

⇒ *Look-ahead* problem

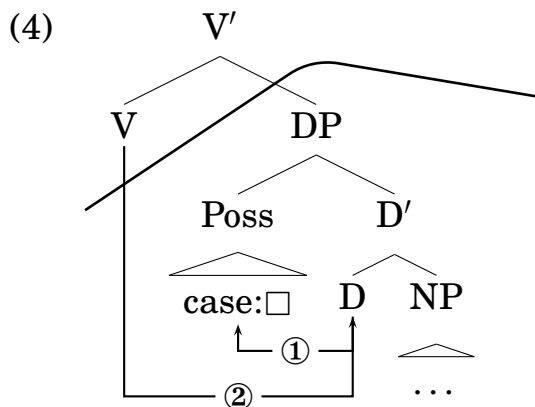

*Note:*

It does not help to assign case to the possessor after the information about the grammatical function is available. This would result in a counter-cyclic derivation:

- If the DP is merged with its selecting head before the possessor is assigned case, the relevant information about the category of the selecting head is available. However, case assignment then involves two elements (the DP internal case assigner and the possessor) that are contained in the DP cycle, but the DP is already dominated by another cycle, i.e. the VP/V'. This dependency thus violates the Strict Cycle Condition, cf. (5).

(5) *Strict Cycle Condition (Chomsky, 1973, SCC):*

- a. No operation can apply to a domain dominated by a cyclic node  $\alpha$  in such a way as to affect solely a proper subdomain of  $\alpha$  dominated by a node  $\beta$  which is also a cyclic node.
- b. Every XP (or: every projection) is a cyclic node.

⇒ *Counter-Cyclicity*

*Solution 1:* assumption 1 is wrong.

The assumption that all syntactic dependencies are local must be wrong. At least possessor case assignment in Udmurt must be non-local.

*Solution 2:* assumption 2 is wrong.

Case assignment is always local, but the case value is not only manipulated at the point when the case value is assigned but additionally in a postsyntactic component.

In what follows, we pursue solution 2. This is supported by the results that will be presented in the following section: The distribution of the ablative does *not* depend on the GF of the containing DP, but rather on its case value, an information that is locally available on the possessor under a case stacking analysis.

### 3 Empirical background

#### 3.1 The Udmurt language

- Udmurt (alternate name: Votyak) is a Uralic language (Permian branch).
- Number of speakers: approx. 500,000
- It is spoken in the Udmurt Republic in Russia (west of the Ural mountains) and in parts of Kazakhstan.
- Almost all speakers are bi- or trilingual: apart from Udmurt they speak Russian and/or Tatar (Csucs, 1988).

#### 3.2 The functions of the ablative

*The ablative as a default semantic case:*

The ablative occurs in a vast variety of contexts. Edygarova (2009, 108) notes that “[the ablative] is used to express comparison, cause, from what material something is done [sic], or as a verb government etc.” The ablative can also be assigned by postpositions and to adjuncts expressing origin and source. Thus, the **ablative is the default semantic case**.

- (6) Edygarova (2009, 108), Winkler (2001, 22-23)
- a. vit'ton-leš uno  
fifty-ABL more  
'more than fifty' *comparison*
  - b. so-leš žad'-em  
he/she-ABL be tired-PRET2/3SG  
'(he) got tired with him' *cause*
  - c. basma-leš lešt-em arberi-os  
cloth-ABL make-PART thing-PL  
'things which are made from cloth' *material*
  - d. ta-leš ažlo  
DEM-ABL before  
'before this' (temporal) *postposition*
  - e. mon so-leš gožtet bašt-i  
I he-ABL letter.ACC get-1SG.PST  
'I got a letter from him.' *source*

Additionally, the ablative case-marks possessors, just like the genitive (cf. (1)).

### 3.3 Case splits and the structural position of the possessor

A case split on the possessor can be found in some other Uralic languages as well (although the factors conditioning the split are different from those found in Udmurt), e.g., Hungarian, Finnish, Estonian, Komi (cf. König & Haspelmath (1998); Nikolaeva (2002); see also Deal (to appear) about a similar alternation in Nez Perce).

The alternation is best studied in Hungarian in which nominative and dative alternate.

(7) *Two possessor cases in Hungarian* (Szabolsci, 1994):

- a. (a) Mari kalap-ja  
(the) Mari.NOM hat-POSS.3SG  
'Mari's hat'
- b. Mari-nak a kalap-ja  
Mari.DAT the hat-POSS.3SG  
'Mari's hat'

Szabolcsi (1984) and Szabolsci (1994) argue that the nominative and the dative possessor occupy different positions in the DP.

*Evidence:*

- The determiner  $a(z)$  obligatorily follows the dative possessor but precedes the nominative possessor, see (7).
- Extraction asymmetries: Only the dative possessor can be extracted out of the DP:

(8) Possessor extraction in Hungarian (Szabolcsi, 1984):

- a. Mari-nak nem ismert-em [t' t növér-é-t]  
Mari-DAT not knew-1SG sister-POSS.3SG-ACC  
'I never knew any sister of Mari.'
- b. \*Mari nem ismert-em [t' t növér-é-t]  
Mari.NOM not knew-1SG sister-POSS.3SG-ACC  
'I never knew any sister of Mari.'

*Conclusion:*

The dative possessor is in a derived position that is the DP-counterpart of SpecC (an operator position that serves as an escape hatch for movement out CP). It is moved to this position from a position lower down in the structure that is associated with nominative.

Is there also evidence for two different positions of genitive and ablative possessors in Udmurt? Answer: No.

- There is no element like the Hungarian determiner relative to which the two possessors align differently.
- There are no extraction asymmetries: Both the genitive and the ablative possessor can be extracted out of the DP, illustrated in (9) for extraposition.

(9) *Extraposition of the genitive and ablative possessor in Udmurt*

- a. man'eryz sytše peres' Mikta-len  
manner.3SG such old Mikta-GEN  
'Such is old Mikta's style.' (Vilkuna, 1997, 224)
- b. valze jusky so-les'  
horse.ACC.3SG unharness.IMP.2SG s/he.ABL  
'Unharness his horse!' (Vilkuna, 1997, 224)

- In Udmurt, unlike Hungarian, there is no evidence from extraction, word order, and/or agreement that genitive and ablative possessors occupy different structural positions. Hence, we assume that the case split does not arise from a difference in positions of the possessor in the DP.

### 3.4 Finding the correct generalization

If there is no asymmetry between the ablative and the genitive when used as a possessor, the question arises as to what is the correct generalization that predicts which case is used. Traditionally, the generalization is that a possessor gets ablative if the DP which contains the possessor is the “direct object”. However, the term “direct object” is ambiguous. There are basically three possible interpretations:

1. *Thematic role:*

The possessor gets ablative if the DP containing it has the macro-role patient.

2. *Position in the tree:*

The possessor gets ablative if the DP containing the possessor is the sister of V.

3. *Case:*

The possessor gets ablative if the DP containing the possessor is assigned accusative.

We tested these interpretations against the data.<sup>1</sup> In the end, only interpretation 3 will be compatible with the data.

*Fact 1:*

A possessor in a passivized subject receives genitive case. Since passivization does not change the thematic role of an argument, interpretation 1 is falsified by the data in (10).

(10) *Possessor case in active-passive alternation:*

- a. Petyr Masha-leš puny-z-e zhug-i-z  
Peter Masha-ABL dog-3SG-ACC beat-1PST-3SG  
'Peter beat Masha's dog.'
- b. Masha-len/\*-leš puny-jez zhug-em-yn val  
Masha-GEN/-ABL dog-3SG beat-PST-PART AUX.1PST  
'Masha's dog was beaten.'

*Fact 2:*

A possessor in a passivized subject that is in the VP (is to the right of temporal adverbs that mark the VP boundary) receives genitive case. This falsifies interpretation 2, since it would predict ablative case instead of genitive case.<sup>2</sup>

(11) *Adverb 'yesterday':*

- tolon Masha-len puny-jez zhug-em-yn val  
yesterday Masha-GEN dog-3SG beat-PST-PART AUX.1PST  
'Yesterday Masha's dog was beaten.'

<sup>1</sup>We would like to thank our informant Svetlana Edygarova (University of Helsinki) for providing us with the data.

<sup>2</sup>Since Udmurt is a head-final language, it cannot be read off from the surface position of the internal argument relative to the verb whether the argument DP is still in the VP or whether it is moved out of the VP; it will precede the verb in any case.

*Fact 3:*

A possessor contained in a DP that bears a case different from accusative receives genitive case. This was shown in (1-a) for nominative case. (12) shows this for dative (a semantic case) and (17) for genitive. (12) falsifies interpretations 1 and 2.

(12) *Dative assigning verb:*

Petyr [Masha-len suzer-ez-ly] akylt-e  
Peter Masha-GEN sister-3SG-DAT bother-PRES.3SG  
'Peter is bothering Masha's sister.'

*Conclusion so far:*

Only interpretation 3 is compatible with the empirical facts.

(13) *Empirical generalization:*

The possessor in Udmurt bears ablative if the DP in which the possessor is contained is assigned accusative. It bears genitive elsewhere.

This generalization is also compatible with the following facts:

*Fact 4:*

The subject of the complement clause of an ECM verb receives accusative case. A possessor contained in such a subject receives ablative case. This falsifies interpretation 2 (and interpretation 1 if one assumes that ECM subjects only receive a thematic role from the embedded verb).

(14) *ECM construction in Udmurt:*

Petyr Masha-leš puny-z-e tyloburdo-os-ty kutyl-e malpa  
Peter Masha-ABL dog-3SG-ACC bird-PL-ACC.PL catch-PRES.3SG think.PRES.SG  
'Peter believes Masha's dog to catch birds.'

Another way to express ECM constructions in Udmurt is to nominalize the embedded clause. In this context, the subject of the embedded clause receives ablative case if the clause gets accusative case. The embedded subject gets genitive elsewhere.

(15) Petyr-len Masha-leš pyny-z-e vi-em-ez myn-ym ug  
Peter-GEN Masha-ABL dog-3SG-ACC kill-PARTC-3SG 1SG-DAT NEG.PRS.1  
jara  
please.CONG.SG  
'[Peter's killing Masha's dog] does not please me.'

(16) mon Petyr-leš Masha-leš puny-z-e vi-em-z-e adzdz-i  
1SG Peter-ABL Masha-ABL dog-3SG-ACC kill-PART-3SG-ACC see-1PAST.1SG  
'I saw Peter killing Masha's dog.' (Lit. 'I saw Peter's killing Masha's dog.')



*Fact 5:*

A possessor of a possessor contained in a DP that bears accusative case receives genitive case (see also Edygarova (2010, 177)).

- (17) Masha-len apaj-ez-len puny-jez iz'-e  
Masha-GEN sister-3SG-GEN dog-3SG sleep-PRS.3SG  
'Masha's sister's dog is sleeping.'
- (18) Petyr Masha-len apaj-ez-leš puny-z-e zhug-i-z  
Peter Masha-GEN sister-3SG-ABL dog-3SG-ACC beat-1PRT-3SG  
'Peter has beaten Masha's sister's dog.'

## 4 Deriving the generalization

*The lexicon:*

- Udmurt exhibits a rich case system, see (19) (cf. Winkler (2001)). We assume that cases are decomposed into the binary features [ $\pm$ obl(ique)] and [ $\pm$ obj(ect)] (cf. Bierwisch (1967)) as shown in (20) for the three structural cases nominative, accusative, genitive.<sup>3</sup> All other cases (ablative, dative, locative, etc.) are semantic cases which consist of a structural case [+obl,+obj] and further semantic features ([ $\pm$ f], [ $\pm$ g], ...).

(19) *Case System in Udmurt*

Structural cases	Semantic cases	
nominative	dative	inessive
accusative	ablative	elative
genitive	caritive	illative
	adverbial	egressive
	instrumental	transitive
	approximative	terminative

(20) *Structural cases*

NOM	[−obl,−obj]
ACC	[−obl,+obj]
GEN	[+obl,−obj]

(21) *Semantic cases*

ABL	[+obl,+obj][−f,−g,...]
DAT	[+obl,+obj][+f,−g,...]
INSTR	[+obl,+obj][−f,+g,...]
...	

The assumption that semantic cases are more complex than structural cases is independently motivated by the fact that in various non-related languages, the markers of the semantic cases are built upon a structural case marker, exemplified by the paradigms in (22) (Arkadiev (2006)).

<sup>3</sup>See also Halle (1997) for a case decomposition that characterizes genitive as oblique and structural.

(22) a. *Case system of Romani*

	'pigeon'
Nom	golumbo
Acc	golumbo-s
Loc	golumbo-s-te
Dat	golumbo-s-ke
Abl	golumbo-s-tyr
Ins	golumbo-s-a

b. *Case system of Naukan Eskimo*

	'dog'
Nom	aɣna-q
Erg/Gen	aɣna-m
Ins	aɣna-m-iŋ
All	aɣna-m-un
Loc1	aɣna-m-i
Loc2	aɣna-kun

2. D heads in Udmurt have exactly two case slots. Consequently, D heads can receive up to two case values (= case stacking, see section 5 for further discussion).

(23) D [ ]<sub>c</sub> [ ]<sub>c</sub>

3. We assume that semantic cases fill two case slots on D rather than one like structural cases, because semantic cases are more complex than structural cases. Similar ideas have been put forward by Béjar & Massam (1999); Richards (2008).

*The syntax:*

1. D assigns genitive case to a possessor in SpecD, v assigns accusative case to the internal argument, and T assigns nominative case to the external argument.
2. In order to model case concord, we assume that case values are assigned to all case-bearing elements in the DPs via *Multiple Agree* (Hiraiwa (2001)). Case assignment will not affect items without case features.
3. The case assignment for structural and semantic cases is identical, i.e., both are assigned in the syntax. For the sake of concreteness, we follow Pylkkänen (2002); Hole (2008) a.o. and assume that semantic cases are assigned by zero adpositions.

Given these assumptions, case assignment in clauses with a possessor proceeds as follows:

(24) *Genitive case assignment in the DP*

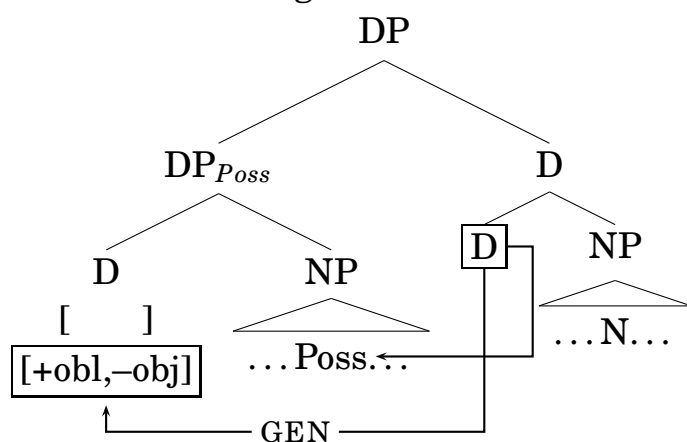

(25) *Nominative case assignment*

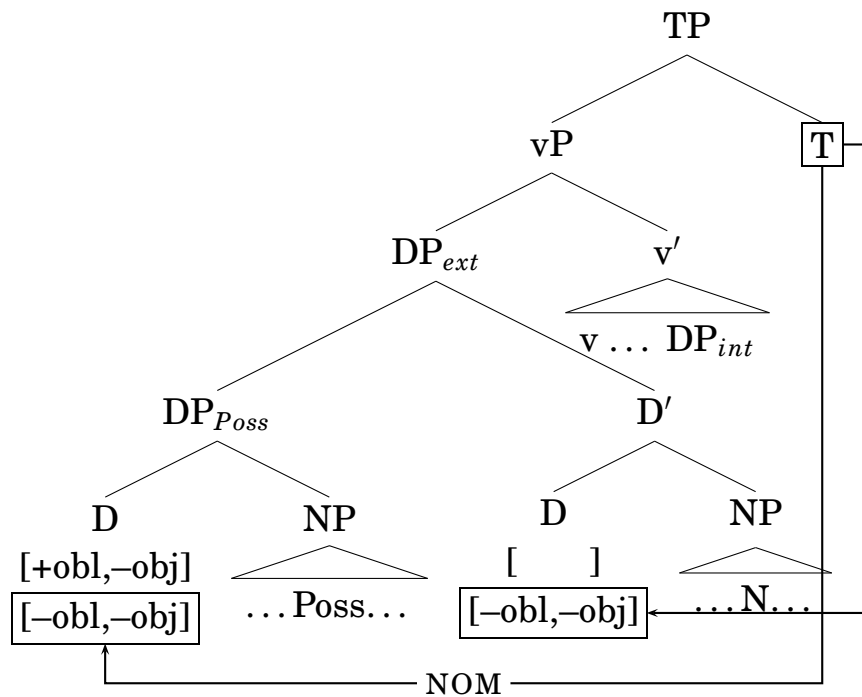

(26) *Accusative case assignment*

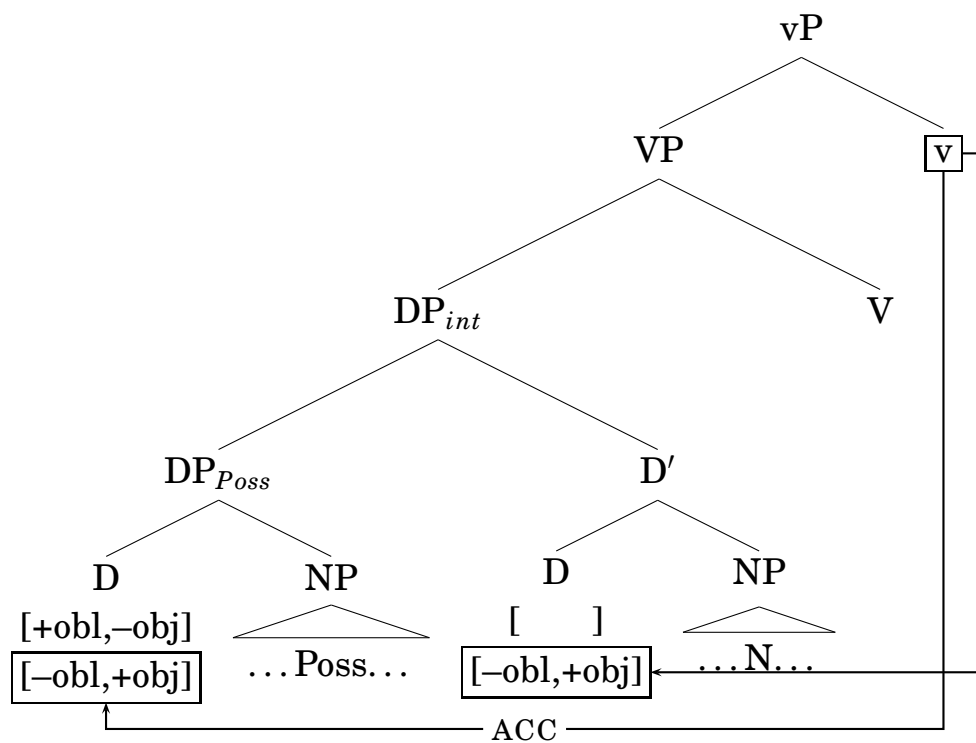

(27) *Dative case assignment*

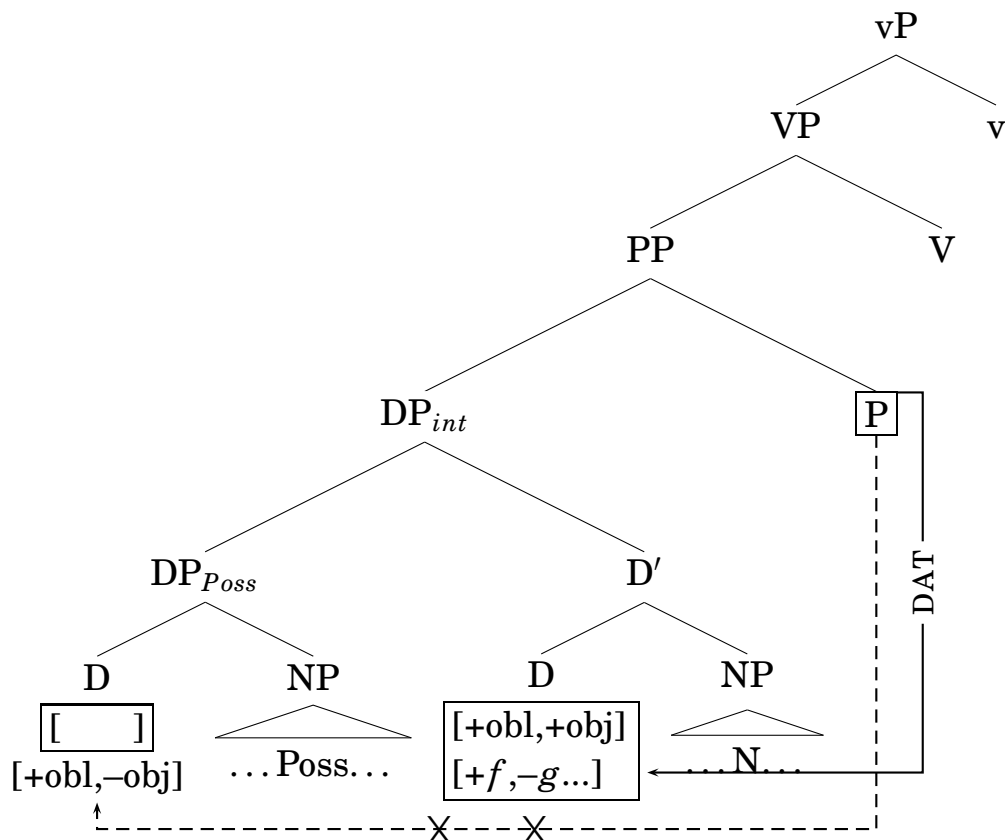

(28) *Double Possessors: Genitive Case Assignment*

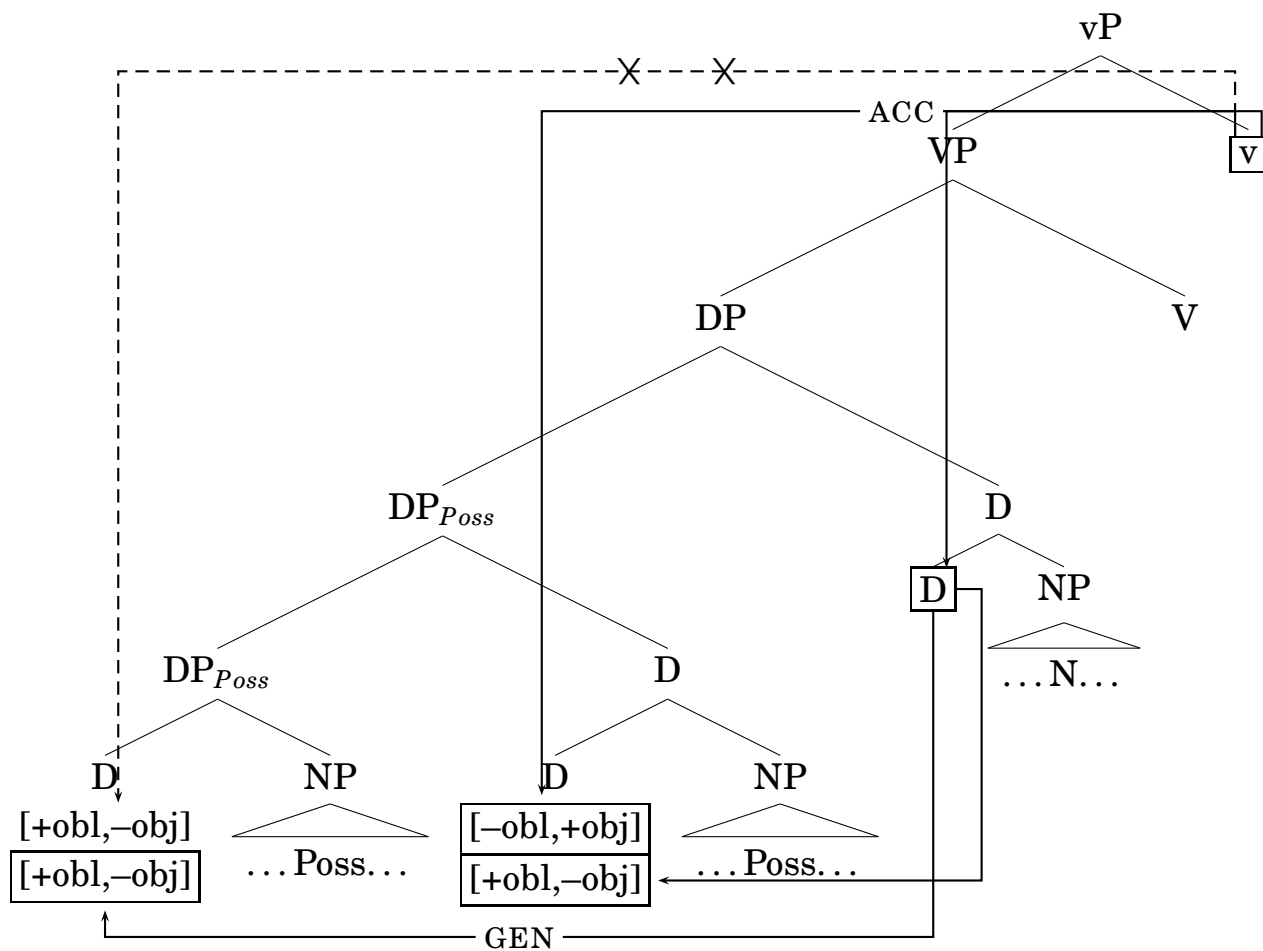

We assume that Udmurt exhibits syntactic case stacking. There are a number of languages that realize both cases morphologically, e.g. Huallaga Quechua in (29). Overt case stacking on possessors is also called *Suffixaufnahme* (cf. Plank, 1995). Udmurt does not allow for overt case stacking, with consequences for the morphological realization.

(29) *Case stacking in Huallaga Quechua (Plank (1995)):*

Hipash-nin-ta            kuya-: Hwan-pa-ta  
daughter-3POSS-ACC love-1 Juan-GEN-ACC  
'I love Juan's daughter.

### *The morphology*

- The case vocabulary items (VIs) are exclusively specified for positive features, cf. (30).
- Case values are realized postsyntactically by the most specific marker that matches the case values (*Subset Principle*; see Halle (1997)).
- Udmurt has a filter which excludes the cooccurrence of two case markers.
- In order to obey the filter, the two case slots on D have to fuse into one. Fusion is a set-building operation which unifies the features of the two case slots into one (if case stacking took place in the syntax). The results of fusion are shown in (31).
- Recall that only structural cases can stack and thus fuse. Any combination of a semantic case and the genitive is excluded already in the syntax. Thus, the genitive case is realized on possessors in a DP with a semantic case, see (31-a).
- Since the nominative has only negative feature values, it will never have an impact on the realization of the case features, see (31-b).
- Since fusion is a set-building operation, identical feature values, as in (31-c) with two genitive case features, are deleted.
- The features of the accusative and the genitive case combine and create a new case value which is both [+obl] and [+obj]. These features must be realized by a semantic case VI, since these VIs are the most specific matching ones. However, since two structural cases have been combined, there are no semantic features ([±f], [±g], ...) in the newly created feature structure. Hence, only the default semantic case VI (not realizing semantic features) can be inserted. This is the ablative VI, see (31-d).<sup>4</sup>

(30) *Vocabulary items in Udmurt:*

[+obl+obj+g]	↔	<en>	(INSTR)
[+obl+obj]	↔	<leš>	(ABL)
[+obl]	↔	<len>	(GEN)
[+obj]	↔	<e>	(ACC)
[ ]	↔	<∅>	(NOM)

<sup>4</sup>Note that the analysis would also work with privative case features instead of binary features: Negatively valued features in the present analysis would simply be encoded by the absence of the privative feature.

(31)	a. <i>gen+dat</i>				
		[+obl, -obj] + [ ]	$\xrightarrow{\text{fusion}}$	[+obl, -obj]	(=genitive VI)
	b. <i>gen+nom</i>				
		[+obl, -obj] + [-obl, -obj]	$\xrightarrow{\text{fusion}}$	[+obl, -obl, -obj]	(=genitive VI)
	c. <i>gen+gen</i>				
		[+obl, -obj] + [+obl, -obj]	$\xrightarrow{\text{fusion}}$	[+obl, -obj]	(=genitive VI)
	d. <i>gen+acc</i>				
		[+obl, -obj] + [-obl, +obj]	$\xrightarrow{\text{fusion}}$	[+obl, -obl, +obj, -obj]	(=ablative VI)
	e. <i>nom+acc</i>				
		[-obl, -obj] + [-obl, +obj]	$\xrightarrow{\text{fusion}}$	[-obl, -obj, +obj]	(=accusative VI)

*Note:*

The analysis presented above naturally accounts for the case pattern with multiple possessors where only the highest possessor can receive ablative case. Lower possessors will receive genitive twice which leaves no slot left for the accusative case to be assigned, which in turn does not create a context where the ablative marker can be inserted.

*Interim conclusion:*

Under the assumption that D heads in Udmurt bear two case slots, Udmurt (sometimes) allows for case stacking in the syntax. Postsyntactic morphological fusion unifies the two case slots (see (31)). In the case of a combination of abstract genitive and abstract accusative features, the case morpheme can only be realized by the ablative marker. In all other combinations of the genitive and another structural case, fusion results in a feature structure that must be realized by the genitive marker.

⇒ **The ablative case on possessors is not an abstract syntactic case** (there are no semantic case features on the possessor that are part of the abstract ablative case). Rather, the ablative exponent is the most specific matching VI if abstract genitive and abstract accusative fuse into a single feature structure.

## 5 Discussion of the consequences

*Look-ahead and counter-cyclicity revisited*

In Udmurt, the possessor of a DP that bears accusative case receives ablative case instead of genitive case.

This phenomenon can be derived without look-ahead in terms of case stacking:

- New generalization: The possessor gets ablative if the DP containing it receives accusative case.
- The new generalization facilitates a local reanalysis of the case split.
- The possessor is always assigned genitive in the DP, and it gets the case from the external head which selects the DP. Both of these case assignments are local.
- In the postsyntactic morphological component, the information which case has been assigned to the entire DP is locally available on the possessor DP due to Multiple Agree, as is the information about the possessor's abstract case.
- Fusion of case features and the specification of the case exponents finally result in two different case exponents on the possessor, which never bears abstract ablative.

*Locality of case assignment is given without locality restrictions:*

In the analysis above, the case assigner can in principle be far away from the case assignee. However, since the number of case slots of a case assignee is limited and since the case slots are filled as soon as possible, the case assigners that are introduced later, i.e., which are farther away from the case assignee, cannot assign case anymore. Thus, the locality of case assignment arises without locality constraints (like phases).

*Linguistic variation reduces to variation of morphological realization:*

In the analysis below, Udmurt is analyzed as having case stacking even though it does not exhibit overt case stacking. Thus, case stacking can be seen as a very widespread phenomenon, but it is sometimes disguised by the way morphology realizes case stacking.

In fact, in many other languages, similar phenomena have been treated as case stacking, which has been referred to traditionally as *Suffixaufnahme* (cf. Plank (1995); Kibrik (1995); Schweiger (1995); Moravcsik (1995)). Udmurt simply presents one of the four possible realizations of case stacking (cf. Corbett (1995); Moravcsik (1995)):

(32) *Parameter for the realization of several case values:*

- a. Realization of all cases (= case stacking): e.g., Huallaga Quechua (cf. (29))
- b. Realization of only one case:
  - (i) *Allomorphy* (new case):  
Udmurt, Daghestanian languages; Moravcsik (1995, 462): “the two cases are represented by a single portmanteau morpheme.”
  - (ii) *Case attraction* (new case overwrites old case): e.g., Rithangu (Pama-Nyungan, Schweiger (1995, 354f.)), Ancient Greek.
  - (iii) *Case that is assigned first is realized:*  
languages without case stacking that do not apply the allomorphy and the case attraction strategy, maybe German.

(iv) *Phonological repair:*

In some languages, case stacking is possible, but if two stacked case morphemes on the possessor are phonologically identical, one of them is deleted, see, e.g., Jiwari (Pama-Nyungan, Austin (1995)), Old Georgian (Kartvelian, Boeder (1995, 182)), Dyirbal (Pama-Nyungan, Schweiger (1995)).

Note, however, that additional linguistic variation arises from lexical variation: in languages like Udmurt, the number of case slots on a case bearing item is limited to two, while other languages allow more than two case slots, cf. (33). There are indeed languages with overt case stacking that also limit the number of stacked cases to two.

(33) a. *Number of cases limited:*

1. *limited to one:*

no case stacking or allomorphy / case attraction strategy

2. *limited to two:*

in Kanyara and Mantharta languages (West Australia) only two cases can stack, but no more than two cases (cf. Austin (1995)).

b. *Number of cases unlimited:*

e.g. Martuthunira (Pama-Nyungan, Corbett (2006, 135)).

## 6 Conclusion

- Traditionally, the case split in Udmurt is described as being driven by the GF of the DP containing the possessor (i.e., its position in the tree in minimalism).
- The choice of the possessor case in the DP thus seems to require look-ahead.
- We have argued that the case split does not depend on GFs, rather it is determined by the case value the entire DP is assigned.
- The new generalization facilitates a local reanalysis in terms of case stacking.
- The possessor is always assigned genitive in the DP and it is then assigned the case from the external head which selects the DP. Both case assignments are local.
- Since there is only a single slot for a case marker in Udmurt, the two case features fuse into a single feature structure which is then realized postsyntactically.
- Only in case of a combination of genitive and accusative does a feature structure arise which is realized by the default semantic VI, the ablative exponent. There is no abstract syntactic ablative case on the possessor.
- The analysis does not require look-ahead or counter-cyclic operations.
- The case stacking analysis is independently motivated: Udmurt simply uses one of the various expected strategies to resolve the conflict that arises when more than one set of case features ‘compete’ for a single morphological case slot: fusion.



## References

- Arkadiev, Peter M. (2006), Two-Term Case Systems In Cross-Linguistic Perspective, in B.Gyuris, ed., 'Proceedings Of The First Central European Student Conference In Linguistics', Hungarian Academy of Sciences, Budapest.
- Austin, Peter (1995), Double Case Marking in Kanyara and Mantharta Languages, Western Australia, in F.Plank, ed., 'Double Case: Agreement by Suffixaufnahme', Oxford University Press, New York, pp. 363–379.
- Béjar, Susana & Diane Massam (1999), 'Multiple Case Checking', *Syntax* 2(2), 65–79.
- Bierwisch, Manfred (1967), Syntactic Features in Morphology: General Problems of So-called Pronominal Inflection in German, in 'To honour Roman Jakobson', Mouton, The Hague, pp. 239–270.
- Boeder, Winfried (1995), Suffixaufnahme in Kartvelian, in F.Plank, ed., 'Double Case: Agreement by Suffixaufnahme', Oxford University Press, New York, pp. 151–215.
- Chomsky, Noam (1973): Conditions on Transformations. In: S. Anderson & P. Kiparsky, eds, *A Festschrift for Morris Halle*. Academic Press, New York, pp. 232–286.
- Chomsky, Noam (1995): *The Minimalist Program*. MIT Press, Cambridge, Mass.
- Corbett, Greville G. (1995), Slavonic's Closest Approach to Suffixaufnahme: The Possessive Adjective, in F.Plank, ed., 'Double Case: Agreement by Suffixaufnahme', Oxford University Press, New York, pp. 265–282.
- Corbett, Greville G. (2006), *Agreement*, Cambridge University Press, Cambridge.
- Csucs, Sandor (1988), Udmurt, in D. M.Abondolo, ed., 'The Uralic Languages', Routledge, London, pp. 276–304.
- Deal, Amy Rose (to appear), 'Possessor Raising', *Linguistic Inquiry*.
- Dench, Alan & Nicholas Evans (1988), 'Multiple case marking in Australian languages', *Australian Journal of Linguistics* 8, 1–47.
- Edygarova, Svetlana (2009), 'Attributive Possession in Udmurt Language', *Linguistica Uralica* 45, 101–118.
- Edygarova, Svetlana (2010), *Kategoria Possessivnosti v Udmurtskom Jazyke*, PhD thesis, University of Tartu, Tartu.
- Halle, Morris (1997), 'Distributed Morphology: Impoverishment and Fission', *MIT Working Papers in Linguistics* 30, 425–449.
- Hiraiwa, Ken (2001), Multiple Agree and the Defective Intervention Constraint in Japanese, in O.Matushansky, A.Costa, J.Martin-Gonzalez, L.Nathan & A.Szczegielniak, eds, 'Proceedings of the HUMIT 2000', Vol. 40 of *UCLA Working Papers in Linguistics*, University of California, Los Angeles, pp. 67–80.
- Hole, Daniel (2008), *Dativ, Bindung und Diathese*, Humboldt-Universität zu Berlin, Berlin. Habilitationsschrift.
- Kel'makov, Valentin K. (1993), Udmurtskij Jazyk, in B.Comrie, ed., 'Jazyki Mira: Ural'skie Jazyki.', John Benjamins, pp. 239–255.
- Kibrik, Aleksandr E. (1995), Direct-Oblique Agreement of Attributes in Daghestanian, in F.Plank, ed., 'Double Case: Agreement by Suffixaufnahme', Oxford University Press, New York, pp. 216–229.
- König, Ekkehard & Martin Haspelmath (1998), Les Constructions à Possesseur Externe dans les Langues d'Europe, in J.Feuillet, ed., 'Actance et valence dans les langues de l'Europe', Mouton de Gruyter, Berlin, pp. 525–606.
- Koptjevskaja-Tamm, Maria (2003), Possessive Noun Phrases in the Languages of Europe, in F.Plank, ed., 'Empirical Approaches to Language Typology', de Gruyter, Berlin/New York, pp. 621–722.
- Moravcsik, Edith A. (1995), Summing up Suffixaufnahme, in F.Plank, ed., 'Double Case: Agreement by Suffixaufnahme', Oxford University Press, New York, pp. 451–484.

- Nikolaeva, Irina (2002), The Hungarian External Possessor in a European Perspective, in R.Blokland & C.Hasselblatt, eds, 'Finno-Ugrians and Indo-Europeans: Linguistic and Literary Contacts.', Shaker, Maastricht, pp. 272–285.
- Plank, Frans (1995), (Re-)Introducing Suffixaufnahme, in F.Plank, ed., 'Double Case: Agreement by Suffixaufnahme', Oxford University Press, New York, pp. 3–110.
- Pylkkänen, Liina (2002), Introducing Arguments, PhD thesis, MIT, Cambridge.
- Richards, Marc (2008), Quirky Expletives, in R.d'Alessandro, G. H.Hrafnbjargarson & S.Fischer, eds, 'Agreement Restrictions', Mouton de Gruyter, Berlin, pp. 181–213.
- Schweiger, Fritz (1995), Suffixaufnahme and Related Case Marking Patterns in Australian Languages, in F.Plank, ed., 'Double Case: Agreement by Suffixaufnahme', Oxford University Press, New York, pp. 339–362.
- Suihkonen, Pirkko (2005), On the Categories and Functions Developed from the Possessive and Deictic Suffixes in Udmurt, in C.Hasselblatt, E.Koponen & A.Widmer, eds, 'Lihkun lehkos! Beiträge zur Finnougristik aus Anlaß des sechzigsten Geburtstages von Hans-Hermann Bartens', Harrassowitz Verlag, pp. 401–431.
- Szabolcsi, Anna (1984), 'The possessor that Ran Away from Home', *The Linguistic Review* 3, 89–102.
- Szabolcsi, Anna (1994), The Noun Phrase, in F.Kiefer, ed., 'Syntax and Semantics, vol 27: The Structure of Hungarian', Academic Press, San Diego, pp. 179–274.
- Vilkuna, Maria (1997), Word Order in European Uralic, in A.Siewierska, ed., 'Constituent Order in the Languages of Europe', Mouton de Gruyter, Berlin, pp. 173–233.
- Winkler, Eberhard (2001), *Udmurt*, Vol. 212 of *Languages of the World: Materials*, LINCOM Europa, München.
- 

### *Funding:*

This research is funded by the DFG (Deutsche Forschungsgemeinschaft) within the project "Lokale Modellierung nicht-lokaler Abhängigkeiten in der Syntax" (Local modeling of non-local dependencies in syntax).

<http://www.uni-leipzig.de/~lomo>